

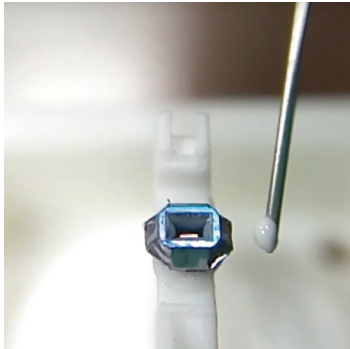

an innovative enclosed specimen holder  
for Liquid TEM



# Wet “Liquid” TEM Kit

K-kit – Silicon-based Micro Channel Device

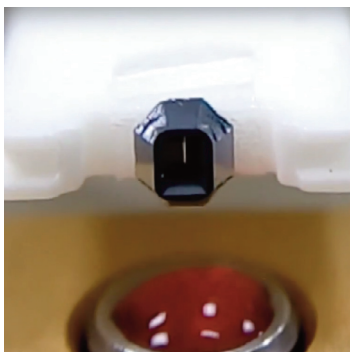
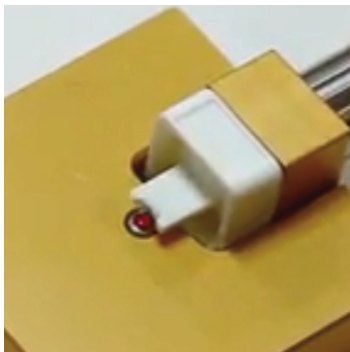

**Electron  
Microscopy  
Sciences**

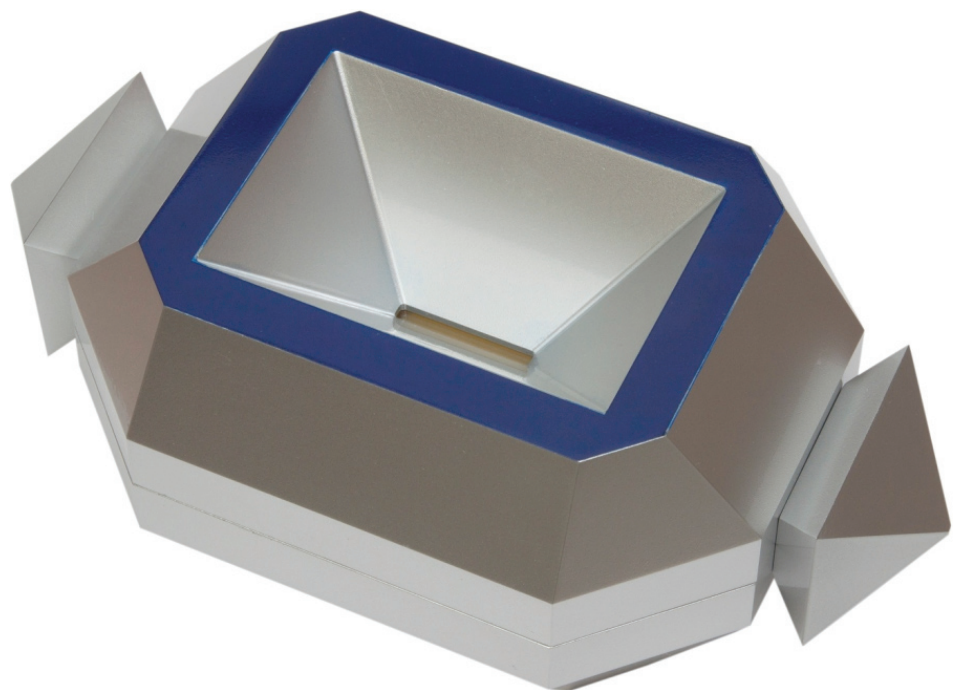
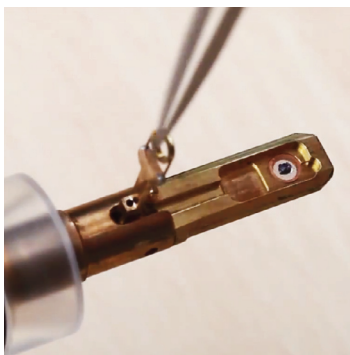

# OVERVIEW

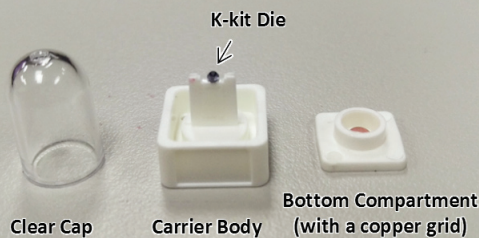

## Why K-Kit?

K-kit Meets All Needs for Liquid TEM

### 1 Native State in Liquid

- Available with undiluted solution.
- Preserve the original morphology and physical state in liquid

### 2 In-situ Observation

- Kinetic mechanism of metal growth or physicochemical reaction process in liquid can be in-situ observed with increased reaction time.

### 3 Quantitative Analysis

- Software of image recognition for nanoparticle size distribution analysis.

### 4 Compatible with Versatile Microscopy Analyses

- Applicable to TEM, FIB, and STEM.
- Available for EDX analysis.
- High resistance to most chemicals.
- Working temperature range from -40°C to 120°C.

Patents being issued and publication:

US 7807979 B2

US 8969827 B2

Anal. Chem.2012, 84: 6312-6316

## Electron Microscopy Sciences

P.O. Box 550 • 1560 Industry Rd.  
Hatfield, Pa 19440

Tel: (215) 412-8400

Fax: (215) 412-8450

email: sgkcck@aol.com

or stacie@ems-secure.com

www.emsdiasum.com

# K-Kit

A Specimen Holder for Liquid Sample Analysis in TEM

## Overview

K-kits are sample holders designed to facilitate convenient TEM observation of liquid samples, allowing nano-objects, aggregates, and agglomerates (NOAAs) in liquid samples to be characterized.

With vacuum compatible sealing of liquids in electron-transmitting thickness, K-kits are micro reaction chambers for countless experiments in materials, chemical, and biological research.

### Features

- Applicable for most TEM holder brands
- Strong structural reliability under vacuum
- Sealing glue compatible to many solvents
- Disposable
- Free of cross-contamination
- Easy to use

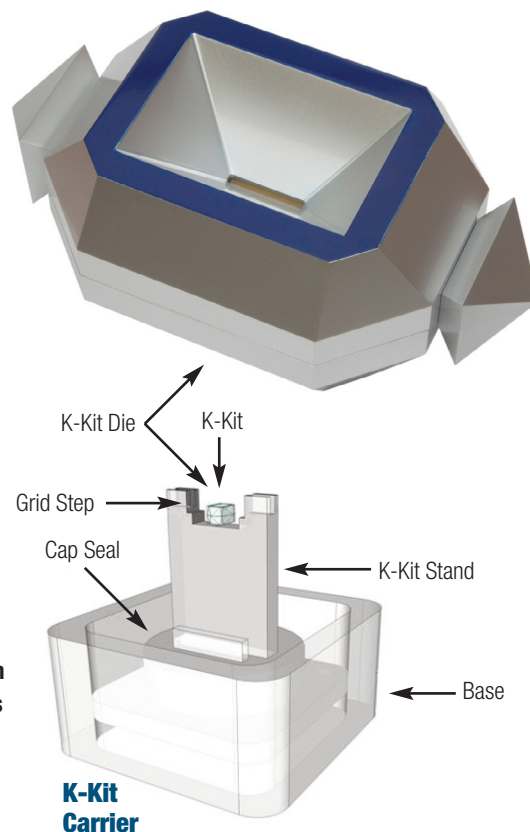

## Sample Analysis Comparison

### K-kit original physical state

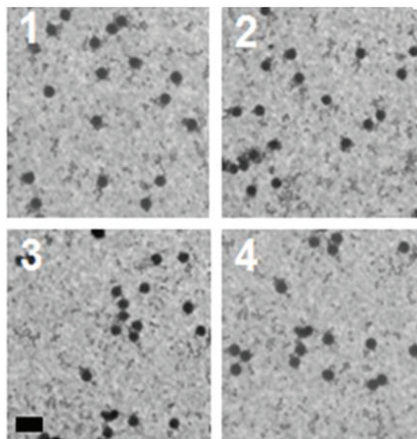

### Conventional aggregated after drying

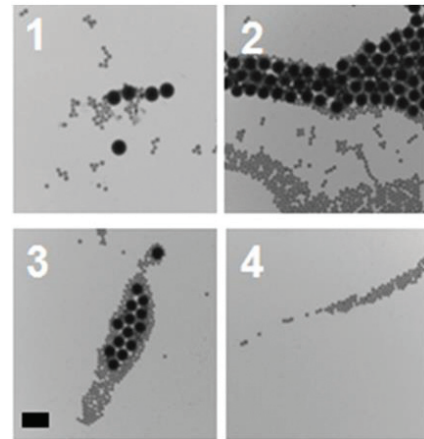

Images shown: NIST traceable polystyrene beads. Scale Bar 500nm.

Physicochemical Parameters	K-kit	Cu-Grid
Composition	✓	✓
Size	✓	✓
Shape	✓	✓
Size Distribution	✓	Δ
Aggregation and Agglomeration <i>in liquid</i>	✓	✗
Particle Concentration	✓	✗
Liquid TEM Observation	✓	✗

✓ = Good Δ = Case Dependent ✗ = Not Available

## K-kit Adaptability

Compatible with all kinds of TEM Holders

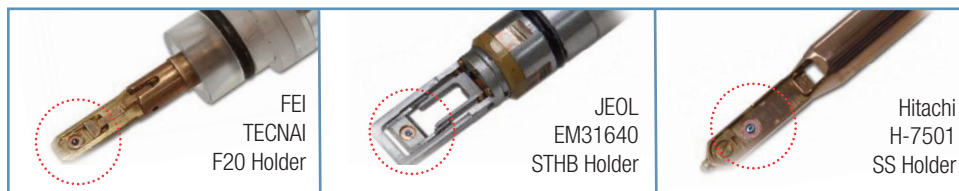
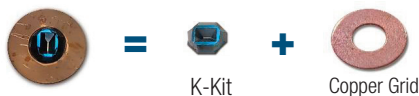

## Strong Structural Reliability under Vacuum

**Silicon Body (MEMS technology):** Use a Si-based structure, ensuring strength and reliability. (MEMS, Micro-Electro-Mechanical Systems)

**Torr Seal® Epoxy:** A trusted and widely-used glue, suitable for high-vacuum systems. (Torr Seal®, a trade mark owned by Agilent Tech. Inc.)

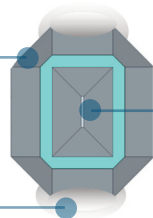

**Silicon Nitride Observation Window:** Material intrinsically tough, durable to withstand drastic pressure changes.

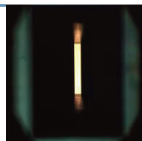

## Sealing glue compatible with many solvents

The following table shows the test results of Torr Seal Epoxy soaked in chemical solvents for 24 hours and then examined using FTIR (if dissolved), and visual observation (if dispersed).

	Water	PEG400	DMSO	Ethanol	0.1N HCl	0.1N KOH
<b>Compatibility (FTIR)</b>	✓	✓	✓	✓	✓	✓
	Hexane	IPA	Methanol	DCM	THF	Acetone
<b>Compatibility (FTIR)</b>	✓	✓	✓	X	X	X

(FTIR, Fourier Transform Infrared Spectroscopy) ✓ = Compatible (FTIR not detected) X = Use with care (FTIR detected)

## Wet and Thin Layer Mode of K-kit

The K-Kit can be used in either Wet Mode or Thin Layer Mode.

**Wet Mode:** The loaded liquid sample is sealed and imaged using TEM in the native liquid environment.

**Thin Layer Mode:** A patented liquid drying protocol preserves the original morphology and physical state of nanomaterials with improved imaging resolution.

Sample Preparation	Wet Mode	Thin Layer Mode
<b>Inner Status of K-kit</b>	With Liquid 	Dried 
<b>Imaging Resolution</b>	Good	Excellent
<b>Gap Size (Considered)</b>	300~500nm	2000~3000nm
<b>Particle Size (Loadable)</b>	10nm~300nm	3nm~2000nm
<b>Particle Shape</b>	Keeping original	Potentially, could be deformed.
<b>Chemical Reduction or Potential Damage by Electron Energy</b>	High	Low
<b>Possible States of K-Kit</b>	Liquid fully filled Liquid partially filled	Thin liquid layer on wall Dry state

## EXAMPLES

### Characterizing NOAAs in liquid

#### Electronics

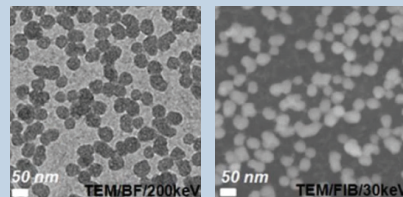

SiO<sub>2</sub> Nanoparticles in Polishing Slurry

#### Food & Beverage

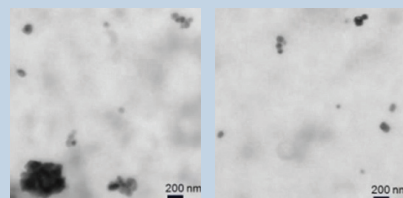

CaCO<sub>2</sub> Nanoparticle Additives in Milk

#### Cosmetics

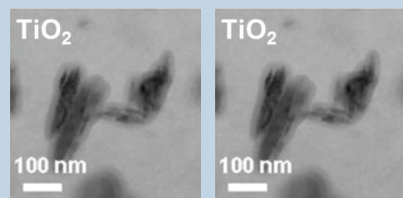

TiO<sub>2</sub> and ZnO Nanoparticles in Sunscreen Lotion

#### Pharmaceuticals

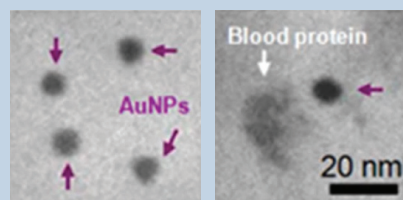

Gold Nanoparticles (AuNPs) in Blood

**Electron  
Microscopy  
Sciences**



## EXAMPLES

### Multiple Loading Application

With an unibody structure, K-kit can be capable of multiple liquid loadings that are usually required in some significant biological applications such as negative staining for low contrast bio samples, studies of catalytic reaction mechanisms, or image-based immunoassay development.

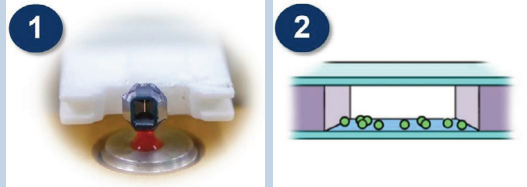

1st K-kit loading with liquid A (such as liposomes/LDL).

The K-kit prepared in dry mode for liquid A

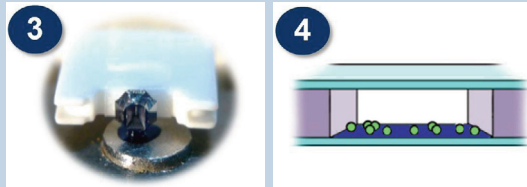

2nd K kit loading with liquid B (such as staining solution).

The K kit in dry mode again for liquid B.

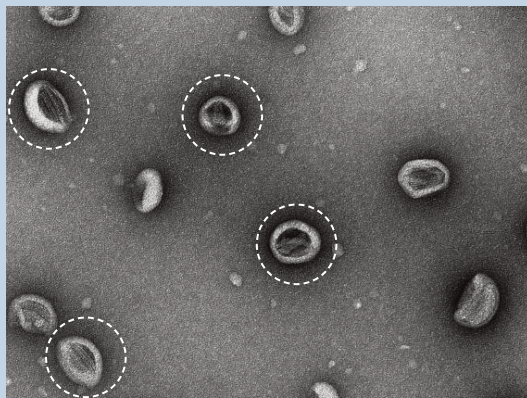
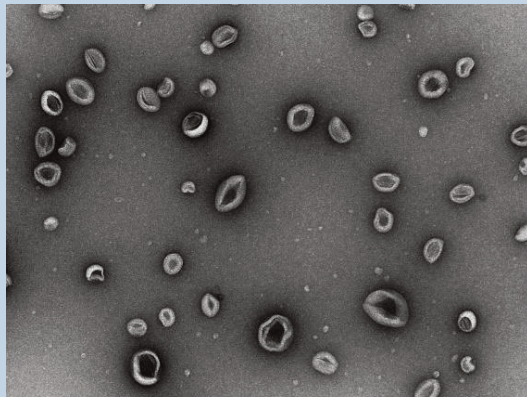

#### Doxorubicin @liposome

Liposomes could be clearly observed in TEM, by using K-kit with negative staining

## Liquid-TEM Observation

### Sample Preparation & Observation:

- Hitachi HT7700 TEM @ acc. voltage of 100KV
- Gap0.2um/SiN30nm K-kits to be applied
- With negative staining by 0.25% UA (Uranyl Acetate)

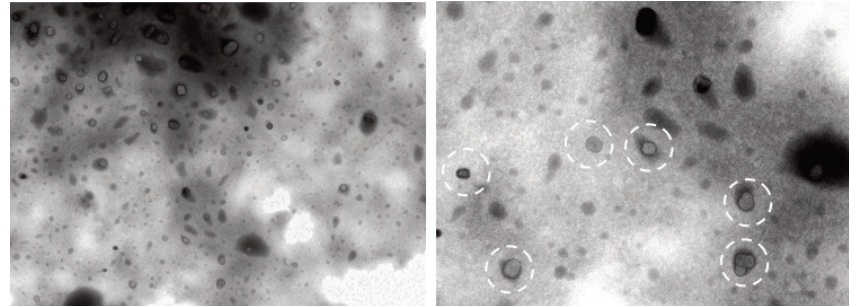

#### Extracellular Vesicles (Exosomes) of Platelets

The extracellular vesicles which released from platelets could be observed by using K-kit.

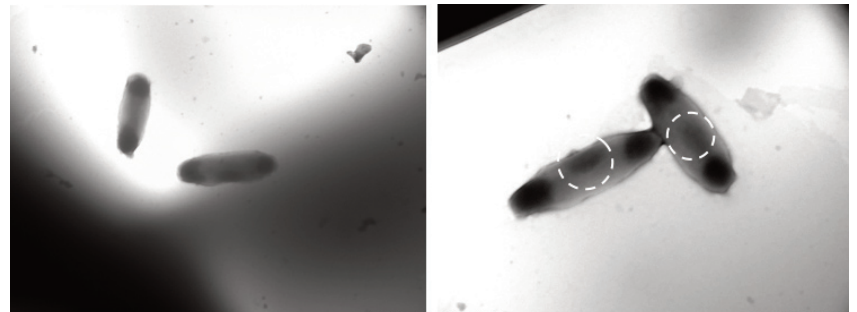

#### E.coli

The nucleoid of E.coli could be observed in TEM using K-kit

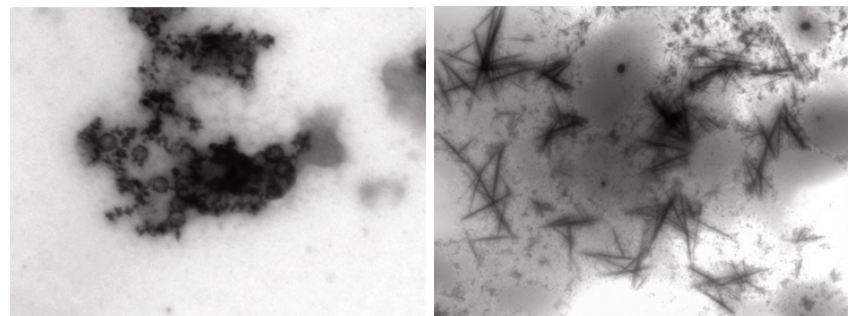

#### Collagen

Collagen molecules aggregate in liquid to form nanofiber structures.

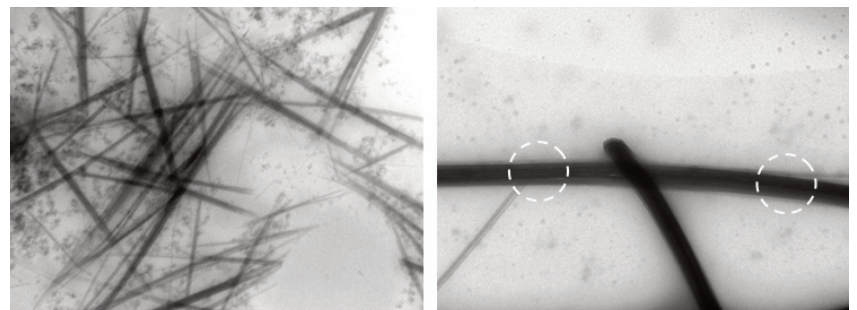

#### Collagen

The packing structure of collagen could be observed in TEM using K-kit.



## Liquid-TEM Observation in Nanopharmaceuticals

**Applicable particle concentration for K-kit:  $10^{11} \sim 10^{14}$  particles/ml**

AuroVist® solution was directly loaded and sealed in a K-kit in liquid form.

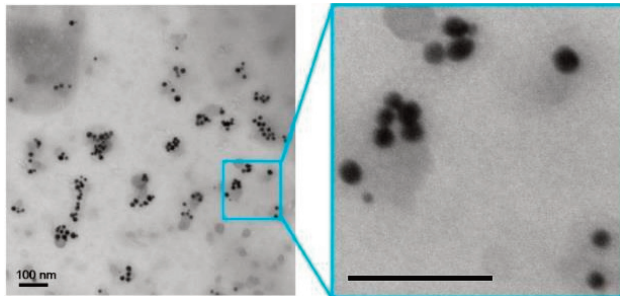

Oil emulsion in water was loaded and sealed in a K-kit in liquid form.

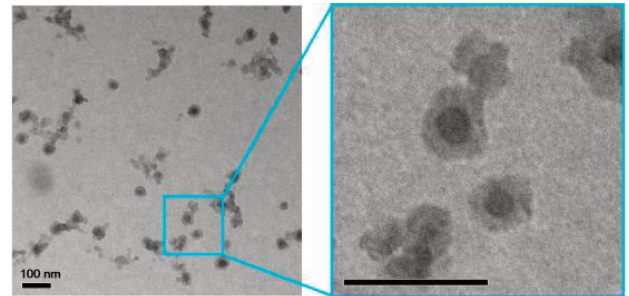

Brand Name of Pharmaceuticals	<b>Doxil®</b> (1995 approved)	<b>Abraxane®</b> (2005 approved)	<b>Aurimune®</b> (Phase II)	<b>Resovist®</b>	<b>Rexin-G®</b> (Phase II)
Particle Size	80-100 nm	~ 130 nm	~ 27 nm (AuNPs core), ~ 30-40 nm as hydrated	~ 45-60 nm (Hydradynamic diameter)	~ 100 nm
Particle Concentrations	$1.0 \times 10^{14}$ liposome /ml	$4.3 \times 10^{13}$ albumin particles /ml	$\leq 1.7 \times 10^{12}$ gold particles /ml	$1 \times 10^{14}$ particles /ml	$1-4 \times 10^{11}$ cfu

Cryo-/ Negative Stain ← TEM Applications in Nanopharmaceuticals → Liquid (K-kit)

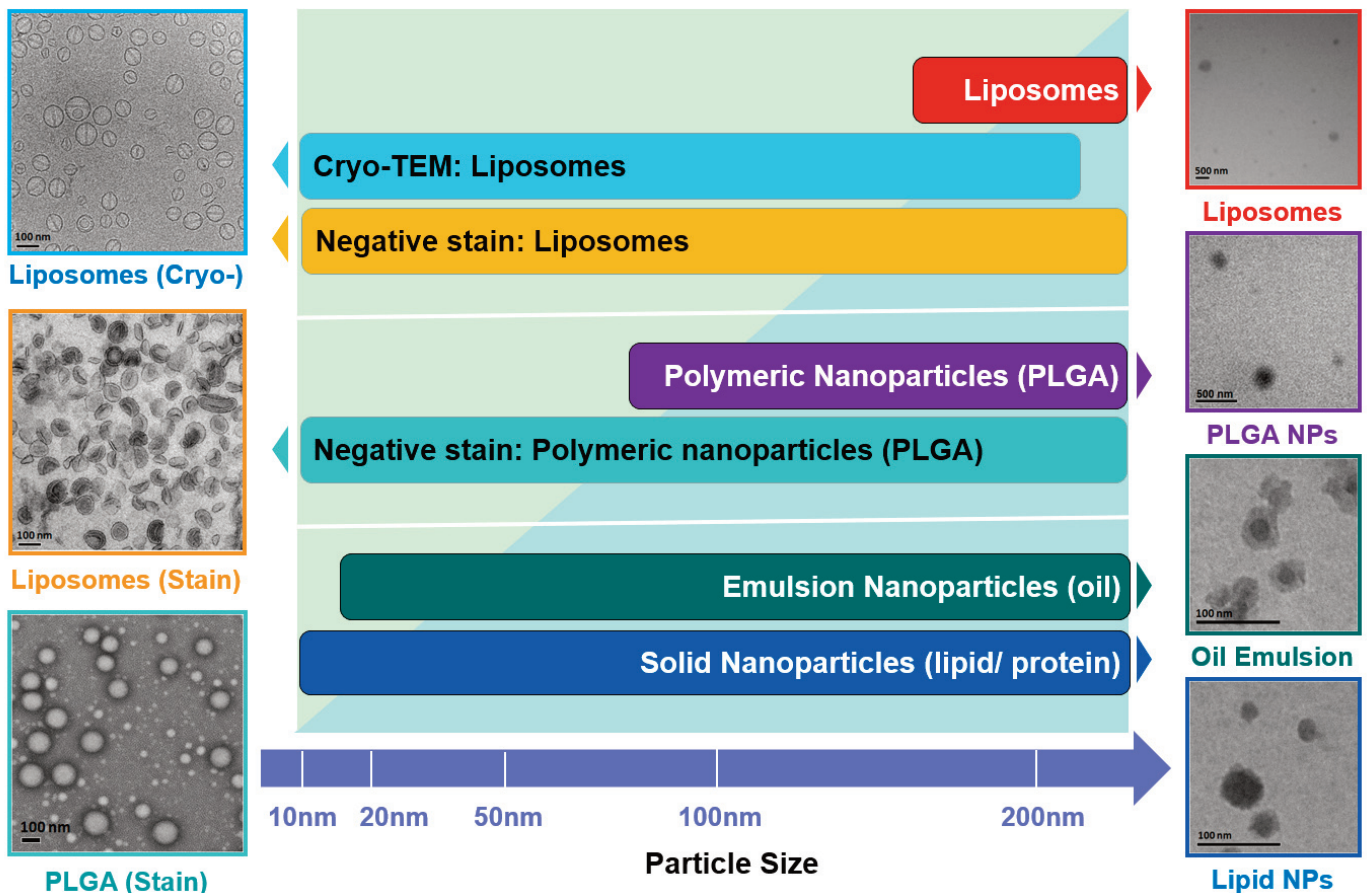





## Abrasives in CMP Slurry

### Primary and secondary particles in undiluted slurry

- Composition
- Shape
- Size/shape distribution
- Aggregation state
- Surface

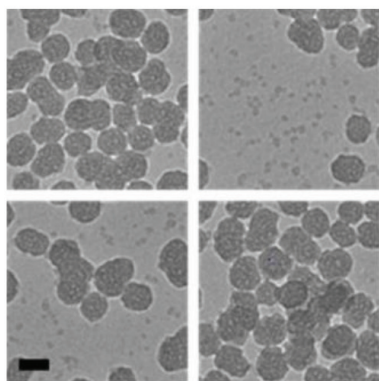
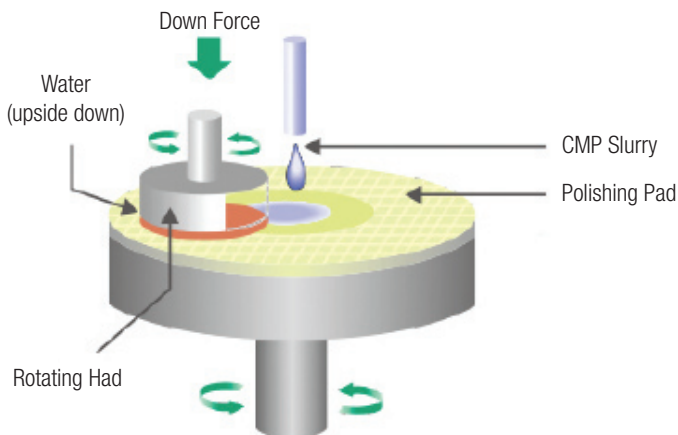

Dried on copper grid

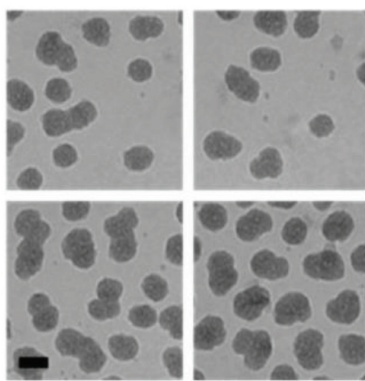

Frozen in Cryo-TEM grid

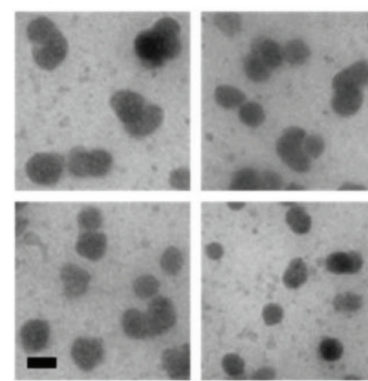

In liquid phase in K-Kit  
\* scale bar is 50nm

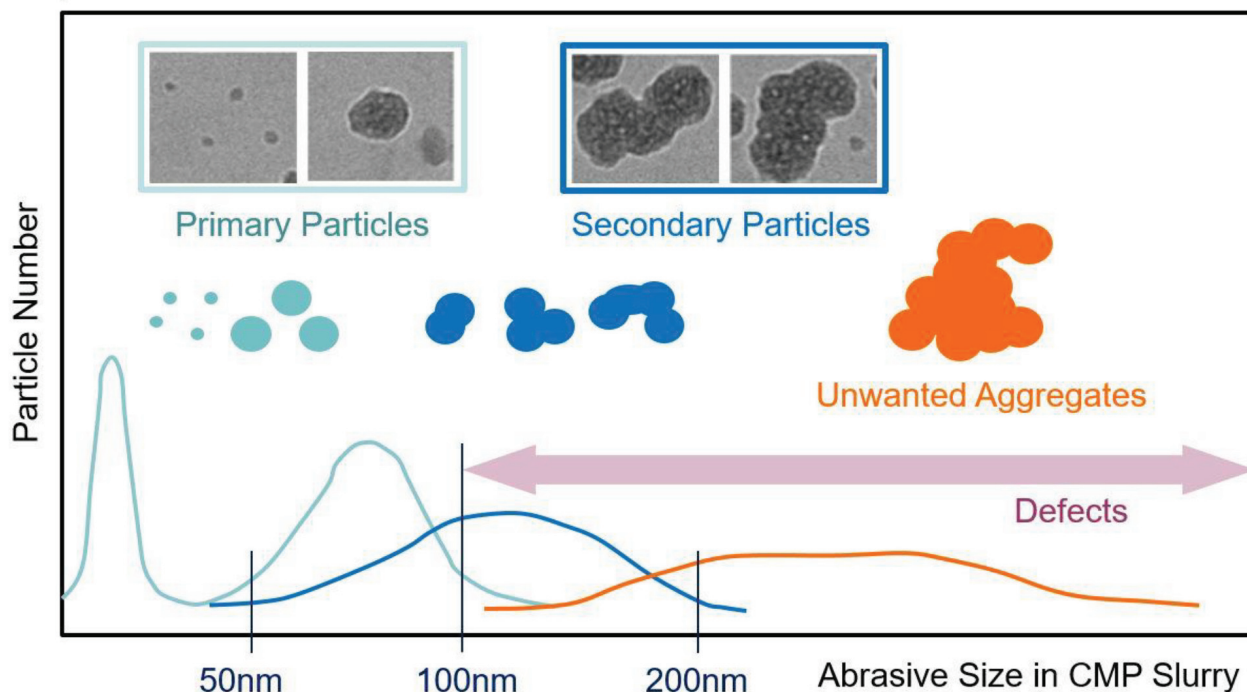
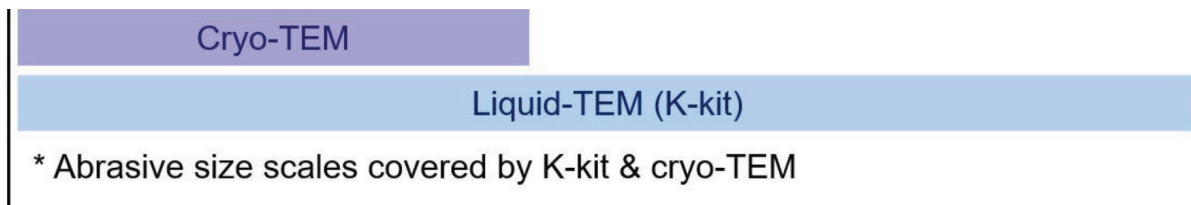





# APPLICATIONS: In-situ Dynamic Observation

## In-situ Dynamic Observation

**The dynamic changes of reaction processes in liquid can be observed and studied by K-kit.**

### Dynamic observation of polystyrene beads in PBS buffer (sodium ion)

The reduction process of sodium ions, induced from the TEM electron energy, in PBS buffer around a polystyrene bead, could be observed.

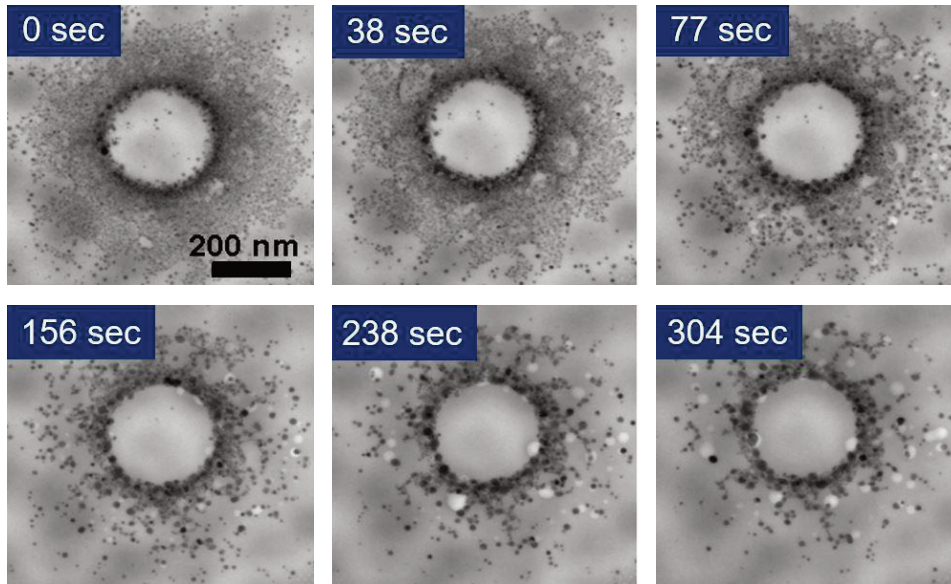

### Gold metal growth in water with and without polystyrene beads

The metal growth of Au ions in water could be observed dynamically at the same time in the areas far away and nearby a polystyrene bead. (As shown in the image, there's a polystyrene bead at the center, with a lot of relatively small Au particles surrounded)

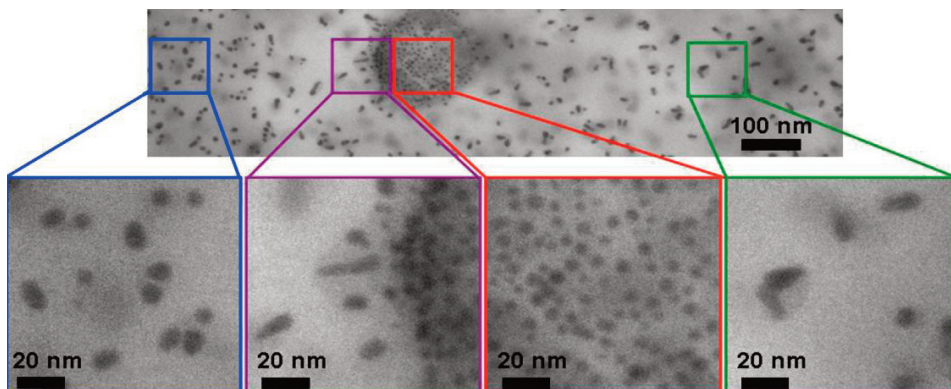

## EXAMPLE:

### Dynamic observation of NOAAs in liquid

#### Dynamic observation of silicate nanoparticles in water

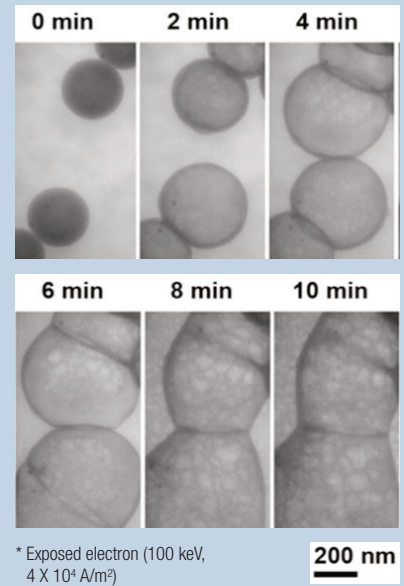

### In situ dynamic observation of polystyrene beads by TEM (Hitachi H-7650)

Observation Environment:  
Vacuum,  $4.0 \times 10^4$  A/m<sup>2</sup>

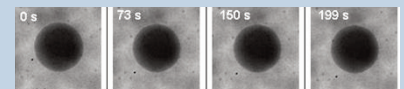

Observation Environment:  
Air,  $2.5 \times 10^3$  A/m<sup>2</sup>

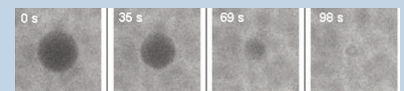

Observation Environment:  
Water,  $2.5 \times 10^3$  A/m<sup>2</sup>

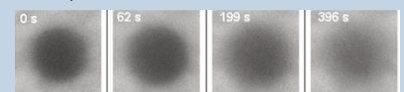

Observation Environment:  
Buffer/PBS (Sodium ion),  $1.0 \times 10^4$  A/m<sup>2</sup>

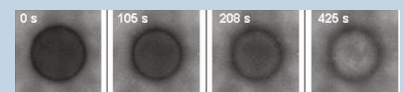

# APPLICATIONS: Quantum Dots

## Quantum Dots in Solution

**Quantum dots will enable a market for devices and components worth over \$11bn by 2026.**

**QD:** Quantum dots  
**BLU:** Backlight Unit

**LCM:** Liquid Crystal Module  
**QDEF:** Quantum-Dot Enhancement Film

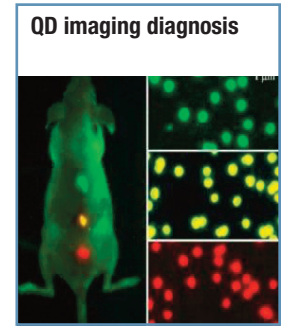
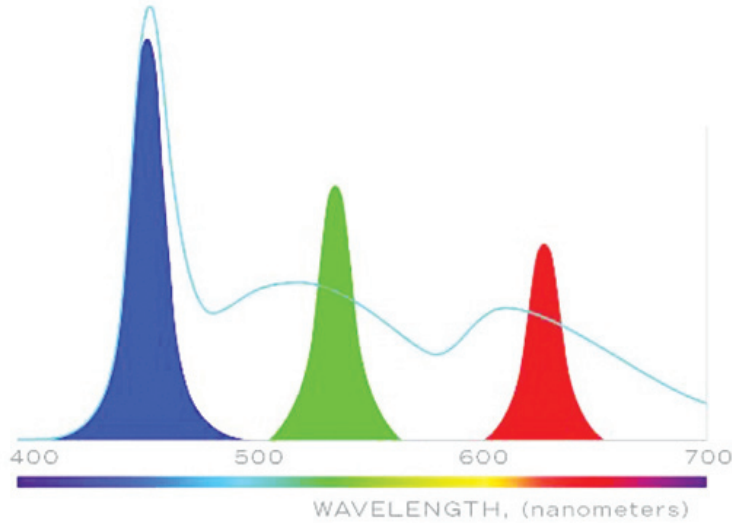
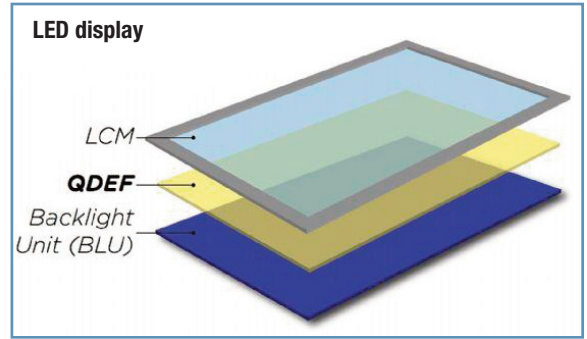

QDs dried on copper grid

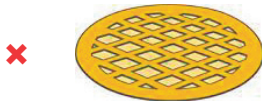

Wet mode of K-kit

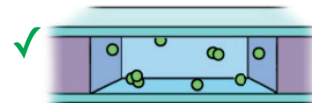

Thin Layer mode of K-kit

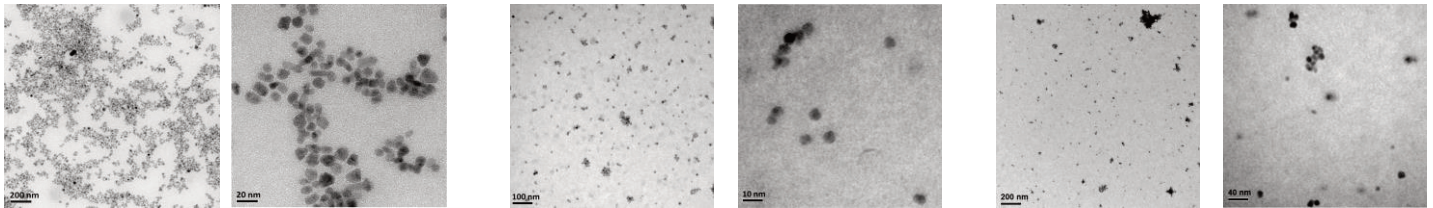
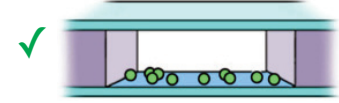

### Size and Size Distribution of QDs in Chloroform (Thin Layer Mode of K-kit)

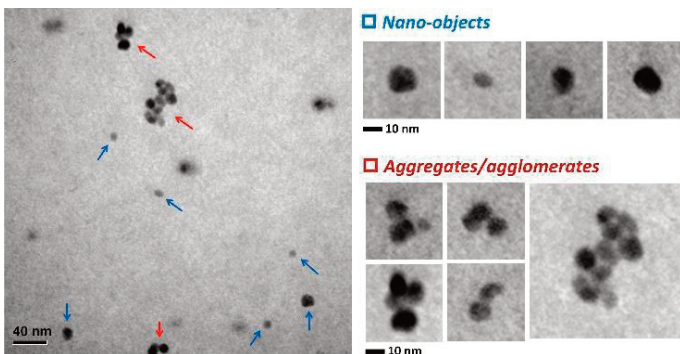

- Sample solution was directly loaded into K-kit
- Nano-objects = Primary particle
- Aggregates/agglomerates = Secondary particle

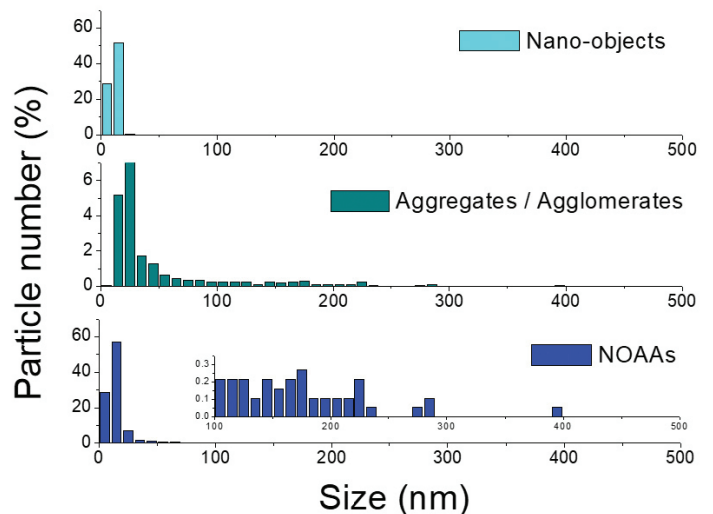



## How to Make EDX Analysis Achievable on a K-kit

By pointing the window long side to the detector and tilting the holder at some angles, which could make the EDX analysis achievable on a K-kit.

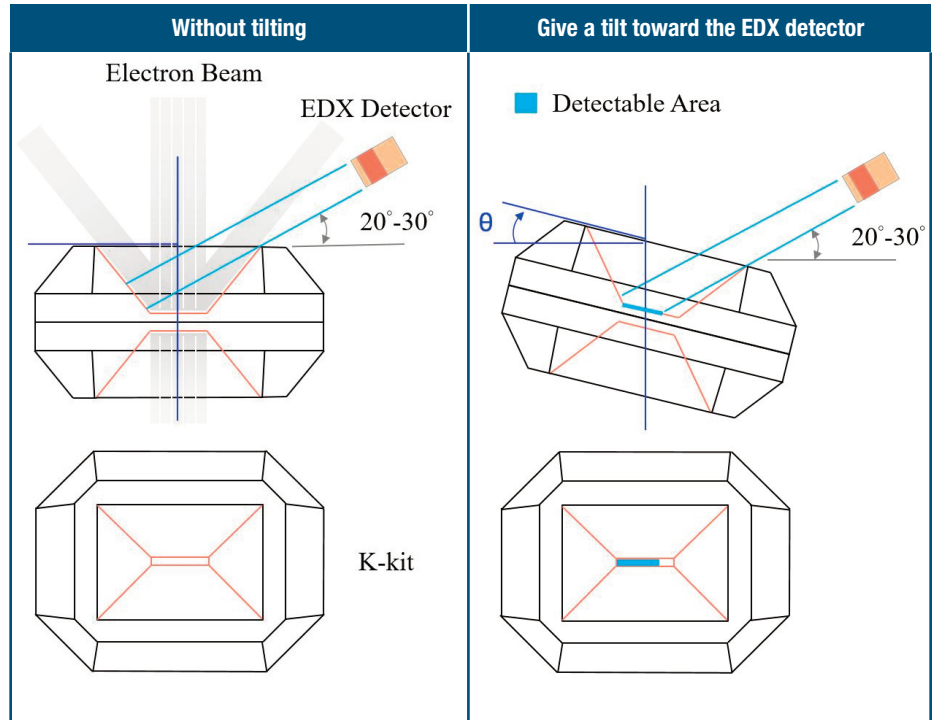
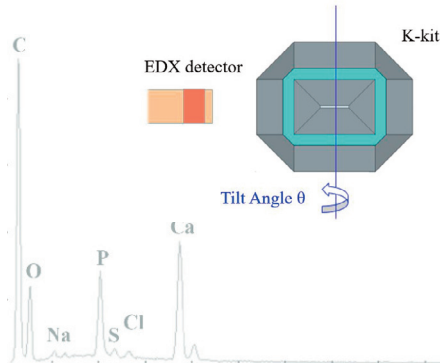

### EDX available angles for different kinds of TEM equipment

Some types of TEM installed with multiple EDX detectors usually can get a clear X-ray excited signal from K-kit, no need to turn any of body rotation or tilting.

#### Example

TEM: Hitachi 7700

EDX: Single Detector

Liquid Sample: AuCl<sub>3</sub>

Tilt Angle: 0°, 10°, 20°

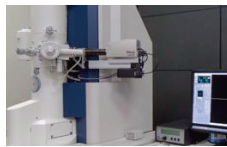

■ Detectable Area

EDX Detector	K-kit	Hitachi 7700	FEI Tecnal-F200	FEI Osilis
Single Detector		$\Theta > 20^\circ$ $\Theta > 20^\circ$	$\Theta > 20^\circ$ $\Theta > 12^\circ$	
Four Detectors				$\Theta = 0^\circ$

$\theta = 0^\circ$

$\theta = 10^\circ$

$\theta = 20^\circ$

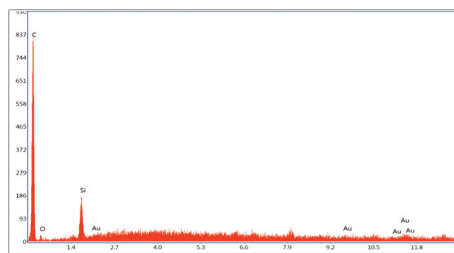

Element	Weight %	Atomic %	Xpt	KAB Factor	Net Int.	Net Error %
C K	75.12	93.74	0.00	1.11	97.83	1.55
O K	0.00	0.00	0.00	1.11	0.00	100.00
Si K	9.55	5.10	0.00	1.00	13.79	8.70
Au L	15.33	1.17	0.00	7.74	2.86	53.67
	100.00					

NG

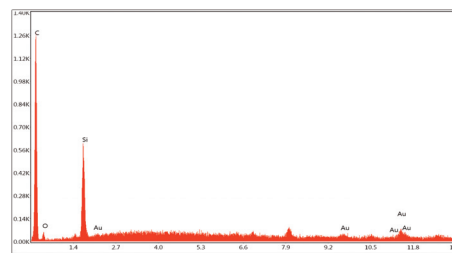

Element	Weight %	Atomic %	Xpt	KAB Factor	Net Int.	Net Error %
C K	60.70	84.82	0.00	1.11	96.91	1.29
O K	0.00	0.00	0.00	1.11	0.00	100.00
Si K	23.09	13.80	0.00	1.00	40.88	3.11
Au L	16.21	1.38	0.00	7.74	3.71	31.09
	100.00					

NG

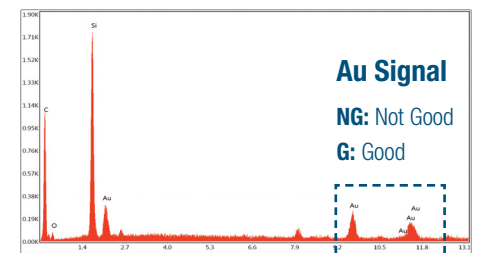

Element	Weight %	Atomic %	Xpt	KAB Factor	Net Int.	Net Error %
C K	15.85	50.56	0.00	1.11	101.28	1.36
O K	0.04	0.10	0.00	1.11	0.27	74.21
Si K	28.18	38.44	0.00	1.00	199.57	1.22
Au L	55.93	10.88	0.00	7.74	51.16	8.91
	100.00					

G

Au Signal  
NG: Not Good  
G: Good

## Matters needing attention when the K-kit is in use



### Inspection Before Use

With Newton's rings on the membrane. (Be sure to keep the channel vacuum sealed)

Silicon body of K-kit should be damage-free.

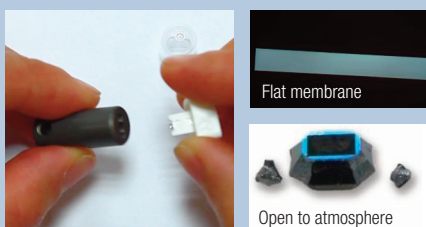

### Channel Tips Removal

Be sure to remove both the channel tips before using K-kit.

It should be finished the liquid loading within 0.5 hour, after breaking the channel tips.

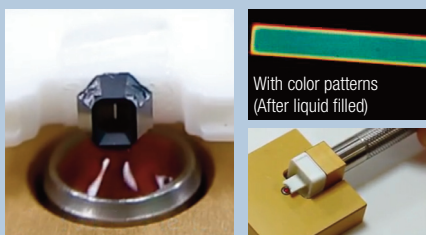

### Liquid Loading

Keep the K-kit steadily touching on liquid for around 1 minute, to allow the filling to complete.

Do not immerse the K-kit in liquid.

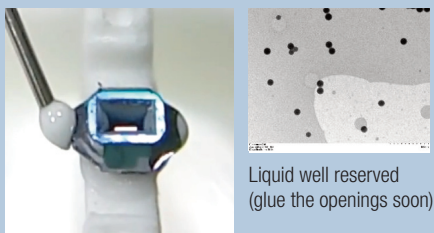

### Gluing Process

Glue both ends of the channel within 1 minute after liquid loading.

Be sure not to do the channel gluing step, if making for Thin Layer mode of K-kit.

Take care during the gluing step, to avoid the glue flowing into the observation window.

## SPECIFICATIONS

### K-Kit Carrier

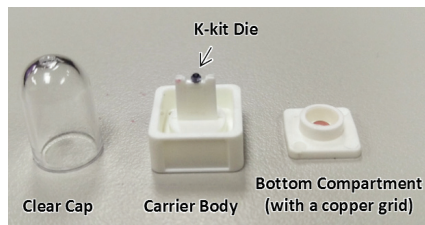

Each carrier has a K-kit attached on top, protected with a clear cap. (A copper grid is enclosed at the bottom of the carrier.)

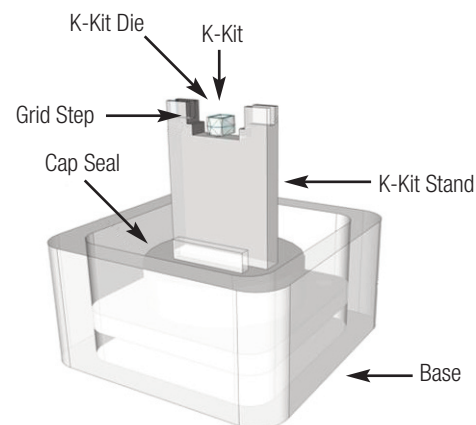

### Dimensions

**Window Length:** 300 $\mu$ m, Width 25 $\mu$ m

**Channel Height (H): 0.2 and 2.0 standard**  
0.5, 1.0 and 5.0 available

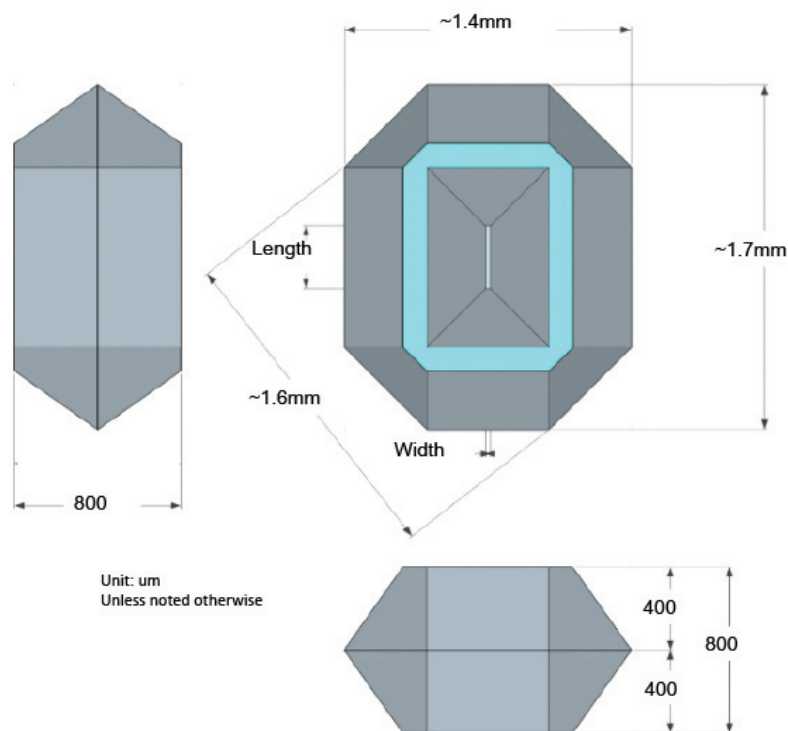
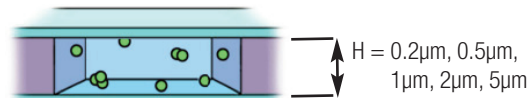



## 1. K-kit

K-kits are Si-based microchannel devices with silicon nitride windows that allow TEM observation. The seemingly irregular shape is a result of KOH anisotropic wet etching, which is also responsible for forming the rectangular observation window in the middle of the device. The liquid channel is parallel to the window, with openings at both ends.

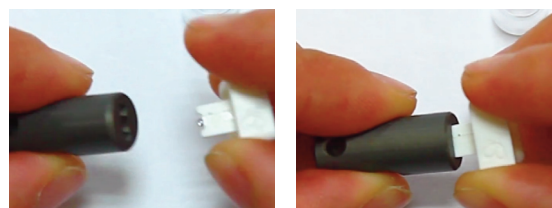
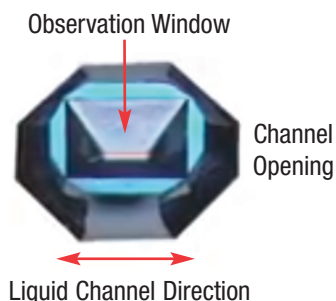

Channel Opener

There are channel tips at each end of the channel to protect the surface condition until before use. Use the channel opener to open the channel by inserting the K-kit carrier top into the opener. Gently push in to the end. The channel opener has a self-guiding slot and a mechanism to break off the tips before the carrier top plate reaches the end.

## 2. Liquid Loading

Place about 2 micro-liter liquid sample at the center of Sample Loading Stage. Place the K-kit carrier at the end of the K-kit holder.

Fit the notch of the holder onto the horizontal rod on the Loading Stage, forming a lever hinged on the rod. This will place the K-kit on the carrier right above the liquid drop. Lower the K-kit to make contact with liquid by gently lifting the back of the K-kit Holder.

Liquid fills the channel through capillary force. The liquid surface is "pulled up" by the K-kit. Keep the K-kit steady for approximately 1 min to allow for the filling to complete. The aqueous liquid sample should be placed on a glass slide. Both the K-kit and glass surface are hygroscopic. Do not immerse the K-kit in liquid.

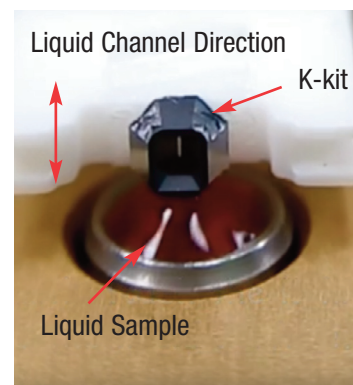
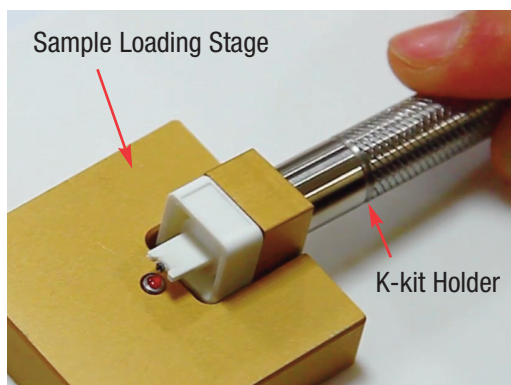

## 3. Vacuum Seal

Place the K-kit carrier on the Gluing Stand. Use Needle Pen to pick and apply the seal epoxy on to the channel openings. Cover the channel openings with adequate amount of seal epoxy.

To ensure the liquid can be well reserved in K-kit, it's strongly recommended to complete the channel-sealed gluing within 1min after liquid loading.



## 4. Copper Grid

Keep the K-kit carrier on the Gluing Stand. Use Needle Pen to pick and apply the Mounting Glue epoxy on to K-kit peripheral. Then, place the supplied copper grid over the K-kit. The steps on carrier top plate facilitate centering and leveling the copper grid.

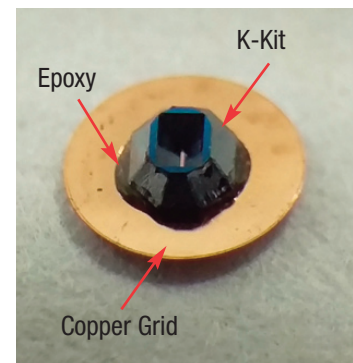
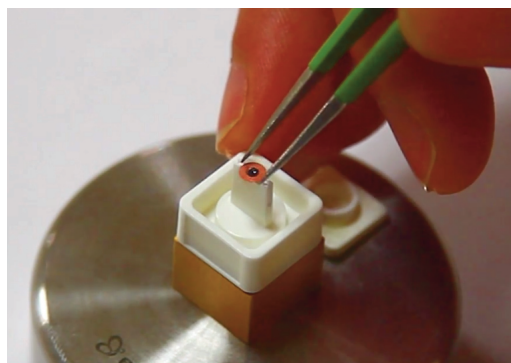

# ORDERING INFORMATION

## COMPONENTS

- Tools are optional available in a Tool Set or ordered individually. The glues are also available.
- Figures are for illustration purposes. The tools you order may be different in color and/or from minor design changes.

### K-kits

Six gap heights (H) available: 0.2µm or 2µm are standard, 0.1µm, 0.5µm, 1.0µm and 5.0µm sizes are also available.

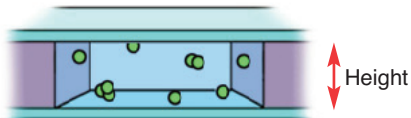

Two membrane SiN thicknesses available: 100nm (standard) and 30nm (thin)

Three package options: 4 or 6 K-kits per pack, or a Tool Box.

Cat No.	Description	SiN Thickness	Qty.
<b>Standard Sizes</b>			
K7260-402	K-kit 0.2	100nm	4/pk
K7261-402		30nm	4/pk
K7260-420	K-kit 2.0	100nm	4/pk
K7261-420		30nm	4/pk
K7260-602	K-kit 0.2	100nm	6/pk
K7261-602		30nm	6/pk
K7260-620	K-kit 2.0	100nm	6/pk
K7261-620		30nm	6/pk

### K-kit Tool Box

The K-kit Tool box houses a full tool set, including K-kit holder, Sample Loading Stage, Needle Pen, Gluing Stand, Channel Opener, Sealing Glue, Mounting Glue, Glass Slides, 6/pk of K-kits, Shipping Box (empty), and some replacement parts.

Also available with everything except the K-kits.

Cat No.	Description	SiN Thickness	Qty.
<b>K-kit Tool Box, 2.0 µm, includes full tool set</b>			
K7261-R	Silver	100nm	each
K7261-T	Silver	30nm	each
K7261-V	Vermilion	100nm	each
K7261-X	Vermilion	30nm	each
<b>K-kit Tool Box, 0.2 µm, includes full tool set</b>			
K7261-S	Silver	100nm	each
K7261-U	Silver	30nm	each
K7261-W	Vermilion	100nm	each
K7261-Y	Vermilion	30nm	each

### Additional Sizes/Quantities

K7260-401	K-kit 0.1	100nm	4/pk
K7261-401		30nm	4/pk
K7260-601	K-kit 0.1	100nm	6/pk
K7261-601		30nm	6/pk
K7260-405	K-kit 0.5	100nm	4/pk
K7260-605		100nm	6/pk
K7260-410	K-kit 1.0	100nm	4/pk
K7260-610		100nm	6/pk
K7260-450	K-kit 5.0	100nm	4/pk
K7260-650		100nm	6/pk

### K-kit Tool Box, 0.1 µm, includes full tool set

K7260-K01	Silver	100nm	each
K7261-K01	Silver	30nm	each
K7260-V01	Vermilion	100nm	each
K7261-V01	Vermilion	30nm	each

### K-kit Tool Box, 0.5 µm, includes full tool set

K7260-K05	Silver	100nm	each
K7260-V05	Vermilion	100nm	each



Cat No.	Description	SiN Thickness	Qty.
<b>K-kit Tool Box, 1.0 µm, includes full tool set</b>			
K7260-K10	Silver	100nm	each
K7260-V10	Vermilion	100nm	each
<b>K-kit Tool Box, 5.0 µm, includes full tool set</b>			
K7260-K50	Silver	100nm	each
K7260-V50	Vermilion	100nm	each
<b>K-kit Tool Box, excludes K-Kits</b>			
K7261	Silver		each
K7262	Vermilion		each



## ACCESSORIES

### K-kit Holder

The K-kit Holder consists of an anodized aluminum header and a stainless steel handle. The K-kit carrier fits on the header (after removing the bottom compartment). When the notch on the side of the header fits over the horizontal bar on the Loading Stage (see below), the K-kit on the carrier attached on the header will be just above the liquid sample.

Cat. No.	Description	Qty.
K7263	K-kit Holder	each

### Needle Pen

The Needle Pen is designed to facilitate the K-kit gluing operation. It has a thin needle 3.0 mm long and 0.27 mm in diameter. The thin needle makes it convenient to pick just enough glue (of the order of 0.1  $\mu\text{l}^{(*)}$ ) for sealing the channel openings and (around 1  $\mu\text{l}^{(*)}$ ) for mounting the copper grid. The needle is made of stainless steel. It is strong, yet slightly flexible, suitable for the job.

#### Notes:

It is important to keep the needle free of residue glue. Please wipe the needle clean right after each use. It will be practically impossible to clean the needle once residue glue on it cures.

The needle is held in place in the pen by a set screw on the side of the pen. A replacement needle and a small Allen key are provided with each Needle Pen. The needle is sharp. Please handle with care.

Cat. No.	Description	Qty.
K7265	Needle Pen	each

### Sample-Loading Stage

The Loading Stage consists of an anodized aluminum body. It has a horizontal bar in a recess on the side and a hole in the middle to house the Liquid Stage, which is a removable stainless steel rod. The removable design is for easy cleaning. The horizontal bar defines the rotational axis for the K-kit Holder, which has a notch on the header to fit on the horizontal bar.

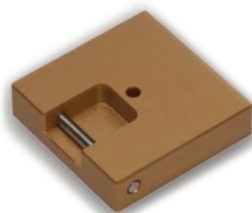

Cat. No.	Description	Qty.
K7264	Sample Loading Stage	each

### Gluing Stand

The Gluing Stand has a stainless steel base and an anodized aluminum header, which is much like the header on the K-kit holder, without the notch on the side. The Gluing Stand keeps the K-kit carrier in place for gluing work.



Cat. No.	Description	Qty.
K7266	Gluing Stand	each

### Channel Opener

The Channel Opener is used to remove the channel tips, while the K-kit stays on the carrier. It's made of anodized aluminum with a cut-off slot design at one end.



Cat. No.	Description	Qty.
K7269	Channel Opener	each



K-kit Holder

Needle Pen

### Accessory Box

The Accessory Box contains sealing and mounting glues, four plastic sticks, and spare parts, including a spare needle, an Allen key for the Needle Pen, a Channel Opener, and two Liquid Stages. (The label can be redesigned.)



Cat. No.	Description	Qty.
K7267	Accessory Box	each

### Starter Box

The Starter Box contains all of the essentials for K-kit loading. It consists of glues, a beaker, four stirring sticks, and two stainless steel thin needles.



Cat. No.	Description	Qty.
K7268	Starter Box	each

### Glue Box

The Glue Box contains recommended sealing and mounting glues, and four plastic stirring sticks.



Cat. No.	Description	Qty.
K7272	Glue Box	each

### Copper Grids

Ten pieces of Copper Grid per pack.

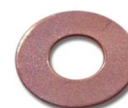

Cat. No.	Description	Qty.
K7270	Copper Grid	10/pk

### Slide-Glass Pack

Six glass slides per pack.



Cat. No.	Description	Qty.
K7271	Slide-Glass Pack	6/pk

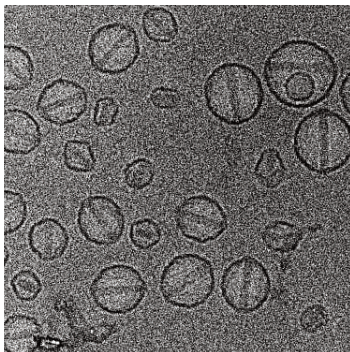
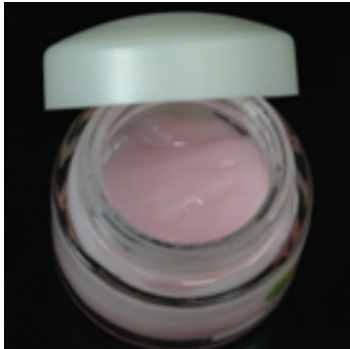

## **Electron Microscopy Sciences**

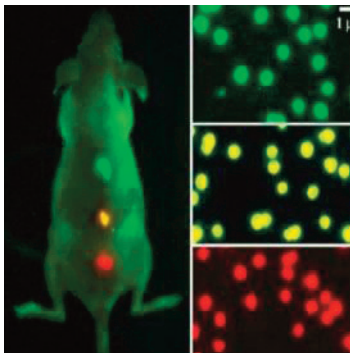

P.O. Box 550 • 1560 Industry Rd.  
Hatfield, Pa 19440  
Tel: (215) 412-8400  
Fax: (215) 412-8450  
email: [info@emsdiasum.com](mailto:info@emsdiasum.com)  
*or* [stacie@ems-secure.com](mailto:stacie@ems-secure.com)  
[www.emsdiasum.com](http://www.emsdiasum.com)